



***BRYTEC***

**AUTOMOTIVE & MARINE  
LED LIGHTING  
CATALOGUE**



# CONTENT & QUICK REFERENCE GUIDE

Page 3	Part No. <small>(Blister pack)</small>	Part No. <small>(OEM)</small>	Series 80	Truck & Trailer Medium
Series 80	BR80ARR	OC80ARR	Triple lamp	Dual stop/tail & indicator
Series 80	BR80ARW	OC80ARW	Triple lamp	Stop/tail, indicator & reverse
Series 80	BR80AR	OC80AR	Double lamp	Stop/tail & indicator
Series 80	BR80A	OS80A	Single lamp	Indicator
Series 80	BR80R	OS80R	Single lamp	Stop/tail
Series 80	BR80W	OS80W	Single lamp	Reverse



Page 4	Part No. <small>(Blister pack)</small>	Part No. <small>(OEM)</small>	Series 100	Truck & Trailer Large
Series 100	BR100ARR	OC100ARR	Triple lamp	Dual stop/tail & indicator
Series 100	BR100ARW	OC100ARW	Triple lamp	Stop/tail, indicator & reverse
Series 100	BR100AR	OC100AR	Double lamp	Stop/tail & indicator
Series 100	BR100A	OS100A	Single lamp	Indicator
Series 100	BR100R	OS100R	Single lamp	Stop/tail
Series 100	BR100W	OS100W	Single lamp	Reverse



Page 5	Part No. <small>(Boxed)</small>		Series Jumbo	Truck & Trailer Jumbo
Jumbo	BRJLARR	Left hand side	Triple lamp	Dual stop/tail & indicator
Jumbo	BRJRRRA	Right hand side	Triple lamp	Dual stop/tail & indicator
Jumbo	BRJLARW	Left hand side	Triple lamp	Stop/tail, indicator & reverse
Jumbo	BRJRWRA	Right hand side	Triple lamp	Stop/tail, indicator & reverse



Page 6	Part No. <small>(Boxed)</small>		Series Jumbo	Truck & Trailer Jumbo
Jumbo	BRJLAR	Left hand side	Dual lamp	Stop/tail & indicator
Jumbo	BRJRRRA	Right hand side	Dual lamp	Stop/tail & indicator
Jumbo	BRJA		Single lamp	Indicator
Jumbo	BRJR		Single lamp	Stop/tail
Jumbo	BRJW		Single lamp	Reverse



Page 7	Part No. <small>(Blister pack)</small>	Part No. <small>(OEM)</small>	Series 140	Truck & Trailer Inserts
Series 140	BR140A	ELRLCA	Round lamp	Indicator
Series 140	BR140R	ELRLCR	Round lamp	Stop/tail
Series 140	BR140W	ELRLCW	Round lamp	Reverse
Series 140		EL140CB	Chrome surround	



Page 7	Part No. <small>(Blister pack)</small>	Part No. <small>(OEM)</small>	Series 160	Truck & Trailer Inserts
Series 160	BR160A	ELRLRA	Rectangular lamp	Indicator
Series 160	BR160R	ELRLRR	Rectangular lamp	Stop/tail
Series 160	BR160W	ELRLRW	Rectangular lamp	Reverse
Series 160		EL160CB	Chrome surround	





Page 8	Part No. <small>(Blister pack)</small>	Part No. <small>(OEM)</small>	Series 120	Circular Lamps
Series 120	BR120AC	EL120AC	Round lamp	Indicator
Series 120	BR120RC	EL120RC	Round lamp	Stop/tail
Series 120	BR120WC	EL120WC	Round lamp	Reverse
Series 120		BRRB	Retro fit bracket	



Page 8		Part No. <small>(OEM)</small>	Series 150	Bullbar Lamps
Series 150		EL150A	Single lamp	Indicator
Series 150		EL150AW	Single lamp	Indicator & front position



# CONTENT & QUICK REFERENCE GUIDE

<b>Page 9</b>	<b>Part No.</b> <small>(Blister pack)</small>	<b>Part No.</b> <small>(OEM)</small>	<b>Series 180</b>	<b>Square Trailer Lamps - 12V</b>	
Series 180	BR180AR	ELSQ100AR	Single lamp	Stop/tail & indicator	
Series 180	BR180ARN	ELSQ100ARNP	Single lamp	Stop/tail, indicator & n/plate	
Series 180	BR180TP		Twin pack	Twin pack (2x ELSQ100AR & wiring loom)	
Series 180	BR180TPNP		Twin pack	Twin pack (1x ELSQ100AR, 1x ELSQ100ARNP & wiring loom)	
<b>Page 9</b>	<b>Part No.</b> <small>(Blister pack)</small>	<b>Part No.</b> <small>(OEM)</small>	<b>Series 25</b>	<b>Number Plate Lamps</b>	
Series 25	BR25B	EL25B	Single lamp	Black 6 LED Number plate	
Series 25	BR25C	EL25C	Single lamp	Opaque 6 LED Number plate	
<b>Page 10</b>	<b>Part No.</b> <small>(Blister pack)</small>	<b>Part No.</b> <small>(OEM)</small>	<b>Series 200</b>	<b>Trailer Strip Lamps</b>	
Series 200	BR200AR	LTL2151	Single lamp	Stop/tail & indicator	
Series 200	BR200A	LTL2151A	Single lamp	Indicator	
Series 200	BR200R	LTL2151R	Single lamp	Stop/tail	
Series 200	BR200W	LTL2151W	Single lamp	Reverse	
<b>Page 10</b>	<b>Part No.</b> <small>(Blister pack)</small>	<b>Part No.</b> <small>(OEM)</small>	<b>Series 203</b>	<b>Submersible Trailer Lamps</b>	
Series 203	BR203	EL203AR	Single lamp	Stop/tail & indicator	
Series 203	BR203NP	EL203ARNP	Single lamp	Stop/tail, indicator & n/plate (horizontal only)	
<b>Page 11</b>	<b>Part No.</b> <small>(Blister pack)</small>	<b>Part No.</b> <small>(OEM)</small>	<b>Series 202</b>	<b>Submersible Trailer Lamps - 12V</b>	
Series 202	BR202L	EL202ARL	Single lamp	Stop/tail & indicator	
Series 202	BR202R	EL202ARR	Single lamp	Stop/tail & indicator	
Series 202	BR202NP	EL202ARNP	Single lamp	Stop/tail, indicator & n/plate (horizontal only)	
Series 202	BR202VNP	EL202VNP	Single lamp	Stop/tail, indicator & n/plate (verticle only)	
Series 202	BR202TP		Twin pack	Twin pack (1x EL202ARL, 1x EL202ARNP & wiring loom)	
<b>Page 12</b>	<b>Part No.</b> <small>(Blister pack)</small>	<b>Part No.</b> <small>(OEM pack of 10)</small>	<b>Series 1 &amp; 2</b>	<b>Marker lamps</b>	
Series 1	BR1AR	OL1-(0.5)	0.5m cable	Side marker (red/amber)	
Series 1	BR1A	OL2-(0.5)	0.5m cable	Side direction indicator (amber)	
Series 1	BR1R	OL3-(0.5)	0.5m cable	Rear end outling marker (red)	
Series 1	BR1W	OL4-(0.5)	0.5m cable	Front end outline marker (white)	
Series 2	BR2AR	OL1-(2.5)	2.5m cable	Side marker (red/amber)	
Series 2	BR2A	OL2-(2.5)	2.5m cable	Side direction indicator (amber)	
Series 2	BR2R	OL3-(2.5)	2.5m cable	Rear end outline marker (red)	
Series 2	BR2W	OL4-(2.5)	2.5m cable	Front end outline marker (white)	
<b>Page 12</b>	<b>Part No.</b> <small>(Blister pack of 2)</small>	<b>Part No.</b> <small>(OEM pack of 100)</small>	<b>Series 140</b>	<b>Reflectors</b>	
Reflectors	BRREFA	ELREFA	65 x 30mm	Amber	
Reflectors	BRREFR	ELREFR	65 x 30mm	Red	
Reflectors	BRREFW	ELREFW	65 x 30mm	White (clear)	

## 5 Year Warranty

### Warranty Statement

All products distributed by Brytec Pty Ltd are covered by a 5 year warranty against defective materials and workmanship unless otherwise stipulated.

Damage or failure arising from faulty or incorrect fitting, incorrect voltage use, misuse, accidental damage, freight or cost of labour will not be covered under Brytec Pty Ltd warranty.

Any warranty claims must be returned to the place of purchase with proof of purchase.

If a two year warranty applies to a product, this will be stipulated in the items description in the catalogue.

# TRUCK & TRAILER LAMPS Series 80

- HIGH QUALITY LED'S (LOW POWER CONSUMPTION)
- POLYCARBONATE LENS & BODY
- HIGH QUALITY RESIN (ADAPTS TO TEMPERATURE CHANGE)
- TINNED COPPER WIRE
- STAINLESS STEEL FITTINGS
- VIBRATION & SHOCK RESISTANT
- MULTI VOLTAGE 10-30V
- BUILT IN REFLEX REFLECTOR
- ADR APPROVED
- CABLE LENGTH (300mm)
- MEASUREMENTS:

SINGLES - 102mm x 94mm x 26mm  
 DOUBLES - 197mm x 107mm x 28mm  
 TRIPLES - 288mm x 107mm x 28mm

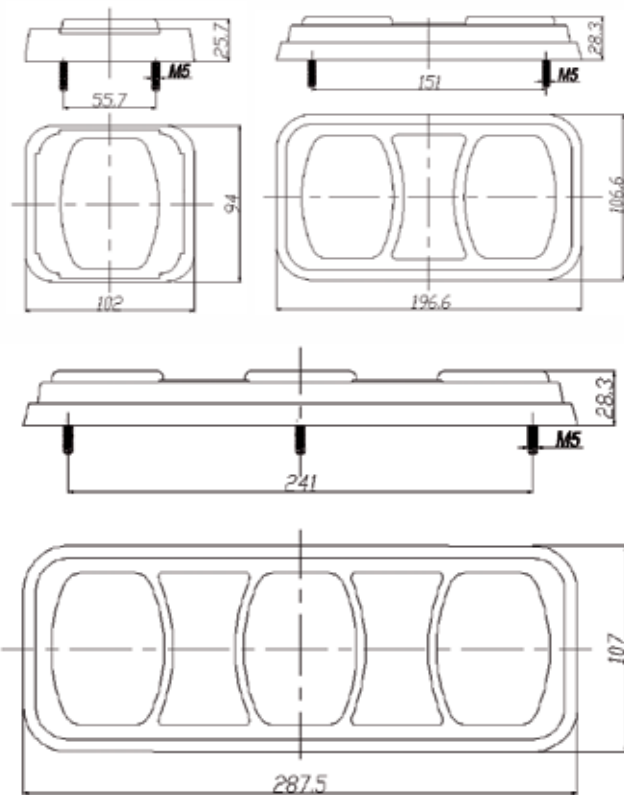

**BR80AR** Blister pack  
**OC80AR** OEM pack

*Stop/tail & Indicator  
 Built in reflex reflector*

ADR - 49/00, 49/00, 47/00, 6/00 (Cat 2a)  
 CRN - 40713, 40712, 40710, 40723



**BR80ARR** Blister pack  
**OC80ARR** OEM pack

*Dual stop/tail & Indicator  
 Built in reflex reflector*

ADR - 49/00, 49/00, 47/00, 6/00 (Cat 2a)  
 CRN - 40713, 40712, 40710, 40723



**BR80ARW** Blister pack  
**OC80ARW** OEM pack

*Stop/tail, Indicator & reverse  
 Built in reflex reflector*

ADR - 49/00, 49/00, 47/00, 1/00, 6/00 (Cat 2a)  
 CRN - 40713, 40712, 40710, 40709, 40723



**BR80R** Blister pack  
**OS80R** OEM pack

*Stop/tail*

ADR - 49/00, 49/00  
 CRN - 40398, 40397



**BR80A** Blister pack  
**OS80A** OEM pack

*Indicator*

ADR - 6/00 (Cat 2a)  
 CRN - 40395



**BR80W** Blister pack  
**OC80W** OEM pack

*Reverse*

ADR - 1/00  
 CRN - 40396

# TRUCK & TRAILER LAMPS Series 100

- HIGH QUALITY LED'S (LOW POWER CONSUMPTION)
- POLYCARBONATE LENS & BODY
- HIGH QUALITY RESIN (ADAPTS TO TEMPERATURE CHANGE)
- TINNED COPPER WIRE
- STAINLESS STEEL FITTINGS
- VIBRATION & SHOCK RESISTANT
- MULTI VOLTAGE 10-30V
- BUILT IN REFLEX REFLECTOR
- ADR APPROVED
- CABLE LENGTH (300mm)
- MEASUREMENTS:

SINGLES - 106mm x 134mm x 36mm  
 DOUBLES - 231mm x 134mm x 36mm  
 TRIPLES - 356mm x 134mm x 36mm

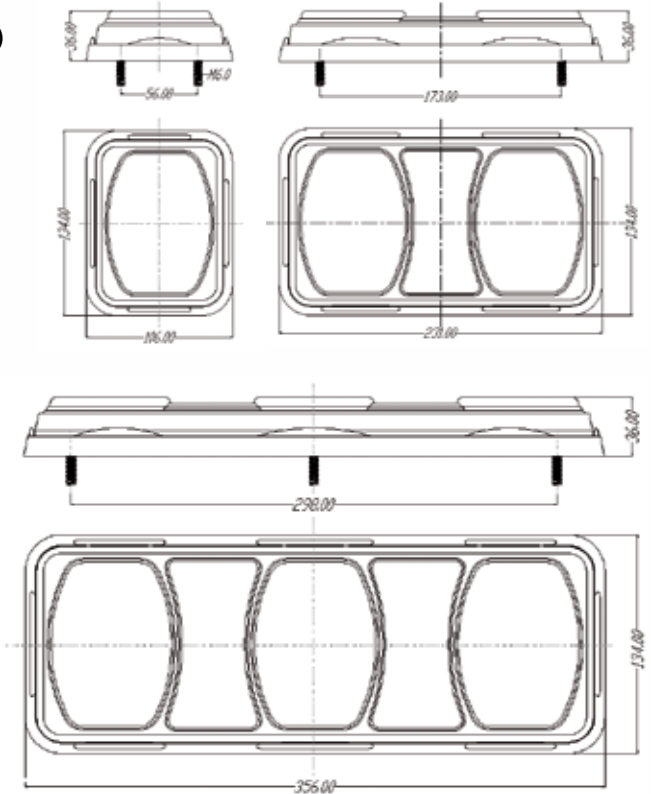

**BR100AR** Blister pack  
**OC100AR** OEM pack

*Stop/tail & Indicator  
 Built in reflex reflector*

ADR - 49/00, 49/00, 47/00, 6/00 (Cat 2a)  
 CRN - 41534, 41536, 41537, 40723



**BR100ARR** Blister pack  
**OC100ARR** OEM pack

*Dual stop/tail & Indicator  
 Built in reflex reflector*

ADR - 49/00, 49/00, 47/00, 6/00 (Cat 2a)  
 CRN - 41534, 41536, 41537, 40723



**BR100ARW** Blister pack  
**OC100ARW** OEM pack

*Stop/tail, Indicator & reverse  
 Built in reflex reflector*

ADR - 49/00, 49/00, 47/00, 1/00, 6/00 (Cat 2a)  
 CRN - 41534, 41536, 41537, 41533, 40723



**BR100R** Blister pack  
**OS100R** OEM pack

*Stop/tail*

ADR - 49/00, 49/00  
 CRN - 41536, 41537



**BR100A** Blister pack  
**OS100A** OEM pack

*Indicator*

ADR - 6/00 (Cat 2a)  
 CRN - 41534



**BR100W** Blister pack  
**OC100W** OEM pack

*Reverse*

ADR - 1/00  
 CRN - 41533

# TRUCK & TRAILER LAMPS Series Jumbo

- HIGH QUALITY LED'S (LOW POWER CONSUMPTION)
- HIGH QUALITY RESIN (ADAPTS TO TEMPERATURE CHANGE)
- POLYCARBONATE LENS & BODY
- TINNED COPPER WIRE & STAINLESS STEEL FITTINGS
- VIBRATION & SHOCK RESISTANT
- MULTI VOLTAGE 10-30V
- BUILT IN REFLEX REFLECTOR
- VOLTAGE LOAD RESISTORS BUILT INTO EACH LAMP
- LOOM PROTECTION OVER CABLING
- WEATHER PROOF CONNECTORS SUPPLIED
- ADR APPROVED
- CABLE LENGTH (300MM)
- MEASUREMENTS 603MM x 130MM x 40MM

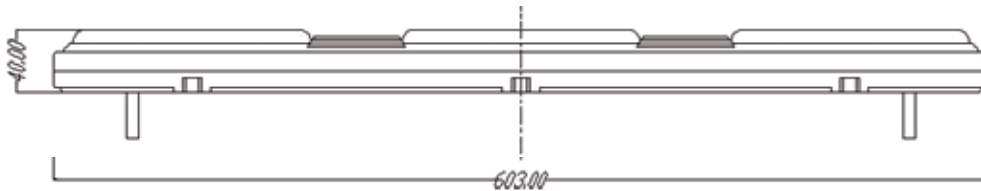
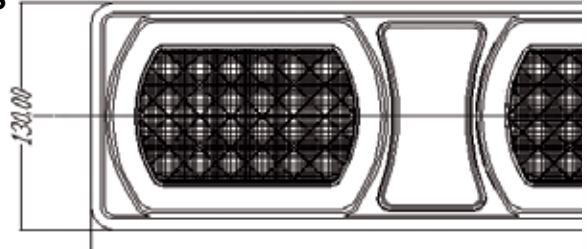

Dual stop/tail & Indicator  
Built in voltage load resistors  
Built in reflex reflector

ADR - 49/00, 49/00, 47/00, 6/00 (Cat 2a)  
CRN - 41099, 41098, 41097, 40723

**BRJLARR**  
**BRJRRRA**

Left hand    Boxed  
Right hand    Boxed



Stop/tail, Indicator & reverse  
Built in voltage load resistors  
Built in reflex reflector

ADR - 49/00, 49/00, 47/00, 1/00, 6/00 (Cat 2a)  
CRN - 41099, 41098, 41097, 40723, 41102

**BRJLARW**  
**BRJRWRA**

Left hand    Boxed  
Right hand    Boxed

# TRUCK & TRAILER LAMPS Series Jumbo

- HIGH QUALITY LED'S (LOW POWER CONSUMPTION)
- HIGH QUALITY RESIN (ADAPTS TO TEMPERATURE CHANGE)
- POLYCARBONATE LENS & BODY
- TINNED COPPER WIRE & STAINLESS STEEL FITTINGS
- VIBRATION & SHOCK RESISTANT
- MULTI VOLTAGE 10-30V
- BUILT IN REFLEX REFLECTOR
- VOLTAGE LOAD RESISTORS BUILT INTO EACH LAMP
- WEATHER PROOF CONNECTORS SUPPLIED
- ADR APPROVED
- CABLE LENGTH (300MM SINGLES & 450MM DOUBLES)
- MEASUREMENTS:

SINGLES - 179mm x 130mm x 40mm  
 DOUBLES - 391mm x 130mm x 40mm

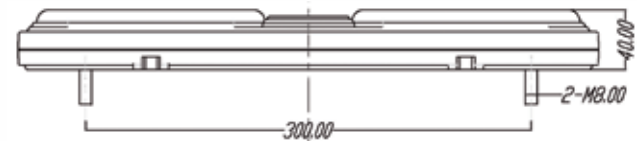
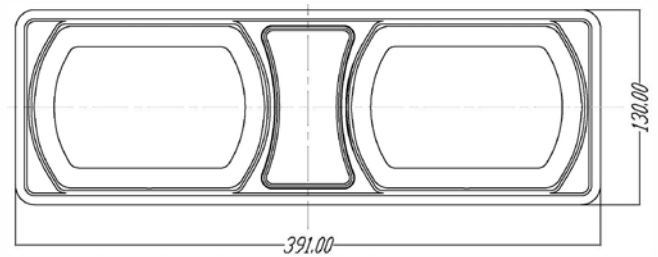
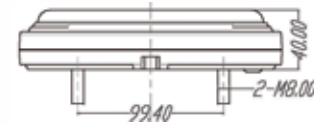
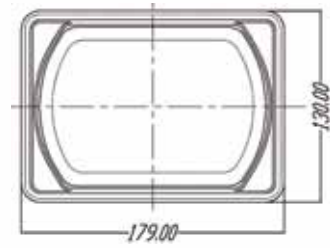

**BRJA** Boxed

Indicator

Built in voltage load resistors

ADR - 6/00 (Cat 2a)  
 CRN - 41097



**BRJR** Boxed

Stop/tail

Built in voltage load resistors

ADR - 49/00, 49/00  
 CRN - 41099, 41098



**BRJW** Boxed

Reverse

Built in voltage load resistors

ADR - 1/00  
 CRN - 41102



Stop/tail & indicator  
 Built in voltage load resistors  
 Built in reflex reflector

**BRJLAR**  
**BRJRR**

Left hand Boxed  
 Right hand Boxed

ADR - 49/00, 49/00, 47/00, 6/00 (Cat 2a)  
 CRN - 41099, 41098, 41097, 40723

# TRUCK & TRAILER LAMPS Series 140 & 160

- HIGH QUALITY LED'S (LOW POWER CONSUMPTION)
- POLYCARBONATE LENS
- VIBRATION & SHOCK RESISTANT
- MULTI VOLTAGE 10-30V
- TINNED COPPER WIRE PLUG & RUBBER GROMMET SUPPLIED (LENGTH 300MM)
- ADR APPROVED
- DIMENSIONS - 138mm DIAMETER x 44mm (Cut out - 116mm dia.)

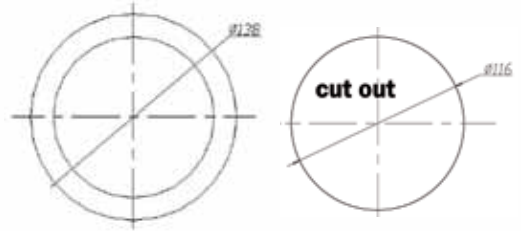

**BR140R** Blister pack  
**ELRLCR** OEM pack

*Stop/tail lamp*

ADR - 49/00, 49/00  
CRN - 40240, 40254



**BR140A** Blister pack  
**ELRLCA** OEM pack

*Indicator lamp*

ADR - 6/00 (Cat 2a)  
CRN - 40220



**BR140W** Blister pack  
**ELRLCW** OEM pack

*Reverse lamp*

ADR - 1/00  
CRN - 40249

- HIGH QUALITY LED'S (LOW POWER CONSUMPTION)
- POLYCARBONATE LENS
- VIBRATION & SHOCK RESISTANT
- MULTI VOLTAGE 10-30V
- TINNED COPPER WIRE PLUG & RUBBER GROMMET SUPPLIED (LENGTH 300MM)
- ADR APPROVED
- DIMENSIONS - 162mm x 114mm x 29mm (Cut out - 139mm x 91mm)

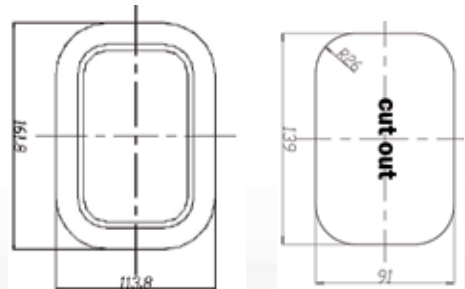

**BR160R** Blister pack  
**ELRLRR** OEM pack

*Stop/tail lamp*

ADR - 49/00, 49/00  
CRN - 40342, 40341



**BR160A** Blister pack  
**ELRLRA** OEM pack

*Indicator lamp*

ADR - 6/00 (Cat 2a)  
CRN - 40225



**BR160W** Blister pack  
**ELRLRW** OEM pack

*Reverse lamp*

ADR - 1/00  
CRN - 40250



**EL140BC** Blister pack  
*Chrome surround suits 140 series*



**EL160BC** Blister pack  
*Chrome surround suits 160 series*

# TRAILER LAMPS Series 120

- HIGH QUALITY LED'S (LOW POWER CONSUMPTION)
- POLYCARBONATE LENS
- TINNED WIRING & STAINLESS STEEL FITTINGS
- VIBRATION & SHOCK RESISTANT
- MULTI VOLTAGE 10-30V
- CABLE LENGTH (300mm)
- RETRO FIT BRACKET AVAILABLE
- ADR APPROVED
- DIMENSIONS - 100mm Dia. x 41mm

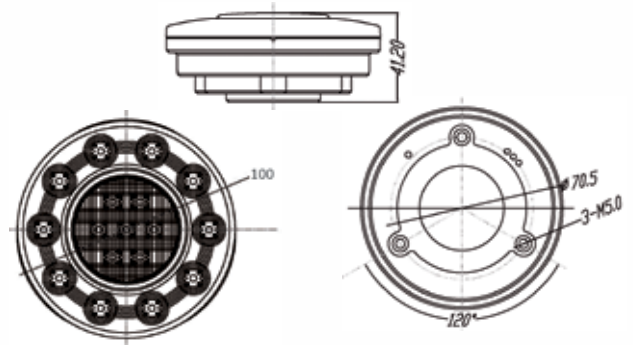

**BR120RC** Blister pack  
**EL120RC** OEM pack

*Stop/tail lamp*

ADR - 49/00, 49/00  
CRN - 41463, 41469

**BR120AC** Blister pack  
**EL120AC** OEM pack

*Indicator lamp*

ADR - 6/00 (Cat 2a)  
CRN - 41467

**BR120WC** Blister pack  
**EL120WC** OEM pack

*Reverse lamp*

ADR - 1/00  
CRN - 41468

**BRRB** Blister pack  
*Retro fit bracket*

# BULLBAR LAMPS Series 150

- HIGH QUALITY LED'S (LOW POWER CONSUMPTION)
- POLYCARBONATE LENS
- FLUSH MOUNTING
- VIBRATION & SHOCK RESISTANT
- MULTI VOLTAGE 10-30V
- CABLE LENGTH (300mm)
- TINNED COPPER WIRE
- ADR APPROVED
- DIMENSIONS - 159mm x 49mm x 33mm

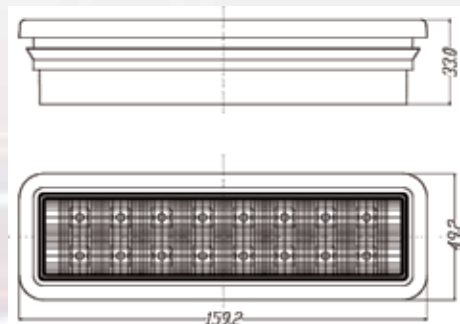

**EL150A**

*Indicator lamp*

ADR - 6/00 (Cat 1)  
CRN - Pending

**EL150AW**

*Front position & indicator lamp*

ADR - 6/00 (Cat 1), 49/00  
CRN - Pending

# TRAILER LAMPS Series 180

- HIGH QUALITY LED'S (LOW POWER CONSUMPTION)
- POLYCARBONATE LENS
- TINNED WIRING & STAINLESS STEEL FITTINGS
- VIBRATION & SHOCK RESISTANT
- BUILT IN REFLEX REFLECTOR
- 12 VOLT ONLY
- CABLE LENGTH (300mm)
- ADR APPROVED

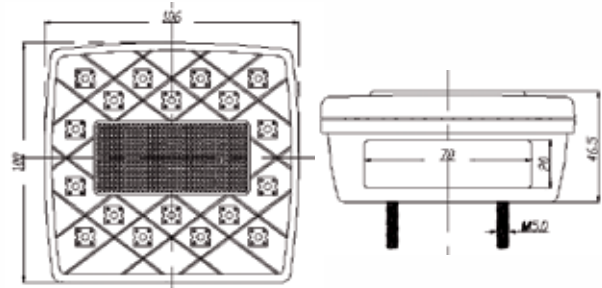

12 VOLT ONLY



**BR180AR** Blister pack  
**ELSQ100AR** OEM pack

*Stop/tail & Indicator*

ADR - 49/00, 49/00, 6/00 (Cat 2a)  
CRN - 41146, 41144, 41143

12 VOLT ONLY



**BR180ARN** Blister pack  
**ELSQ100ARNP** OEM pack

*Stop/tail, Indicator & n/plate*

ADR - 49/00, 49/00, 1/00, 6/00 (Cat 2a)  
CRN - 41146, 41144, 41143, 41142

12 VOLT ONLY



*Cable length (section 1 - 750mm, section 2 - 1600mm, section 3 - 5000mm)*

**BR180TP** Twin pack (w/out n/plate)  
*Stop/tail & Indicator (2x ELSQ100AR & wiring loom)*

ADR - 49/00, 49/00, 6/00 (Cat 2a)  
CRN - 41146, 41144, 41143

**BR180TPNP** Twin pack (with n/plate)  
*Stop/tail & Indicator*

*(1x ELSQ100AR & 1x ELSQ100ARNP & wiring loom)*

ADR - 49/00, 49/00, 6/00 (Cat 2a)  
CRN - 41146, 41144, 41143

# NUMBER PLATE LAMPS Series 25

- 6 HIGH QUALITY LED'S (LOW POWER CONSUMPTION)
- POLYCARBONATE LENS
- TINNED WIRING (CABLE LENGTH - 350mm)
- VIBRATION & SHOCK RESISTANT
- MULTI VOLTAGE 10-30V
- ADR APPROVED
- DIMENSIONS - 81mm x 41mm x 32mm

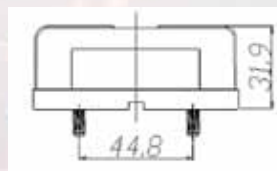

**BR25C** Blister pack  
**EL25C** OEM pack

*Opaque body*

ADR - 48/00  
CRN - 39203



**BR25B** Blister pack  
**EL25B** OEM pack

*Black body*

ADR - 48/00  
CRN - 39203

# TRAILER LAMPS Series 200

- HIGH QUALITY LED'S (LOW POWER CONSUMPTION)
- POLYCARBONATE LENS WITH RUBBER GASKET
- HIGH QUALITY RESIN (ADAPTS TO TEMPERATURE CHANGE)
- VIBRATION & SHOCK RESISTANT
- MULTI VOLTAGE 10-30V
- ADR APPROVED
- TINNED WIRING (300MM) AND STAINLESS STEEL FITTINGS
- DIMENSIONS - 205mm x 40mm x 29mm

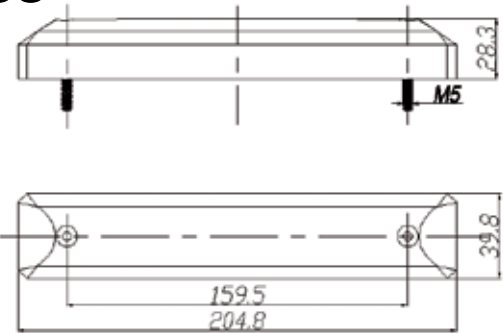

**BR200AR** Blister pack

**LTL2151** OEM pack

*Stop/tail & indicator*

ADR - 49/00, 49/00, 6/00 (Cat 2a)  
CRN - 41100, 41101, 41103



**BR200R** Blister pack

**LTL2151R** OEM pack

*Stop/tail*

ADR - 49/00, 49/00  
CRN - 41093, 41094



**BR200A** Blister pack

**LTL2151A** OEM pack

*Indicator*

ADR - 6/00 (Cat 2a)  
CRN - 41095



**BR200W** Blister pack

**LTL2151W** OEM pack

*Reverse*

ADR - 1/00  
CRN - 41110

# SUBMERSIBLE TRAILER LAMPS Series 203

- HIGH QUALITY LED'S (LOW POWER CONSUMPTION)
- POLYCARBONATE LENS
- TINNED WIRING & STAINLESS STEEL FITTINGS
- VIBRATION & SHOCK RESISTANT
- BUILT IN REFLEX REFLECTOR
- MULTI VOLTAGE 10-30V
- CABLE LENGTH (300mm)
- ADR APPROVED
- DIMENSIONS - 203mm x 92mm x 39mm

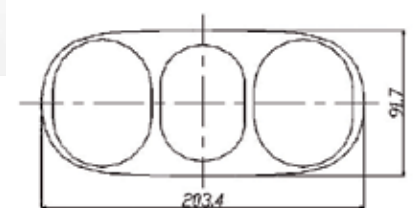

**BR203** Blister pack

**EL203AR** OEM pack

*Stop/tail & Indicator*

*Left hand side*

*Horizontal mount only*

ADR - 49/00, 49/00, 6/00 (Cat 2a)  
CRN - 41006, 41986, 40988



**BR203NP** Blister pack

**EL203ARNP** OEM pack

*Stop/tail, Indicator & number plate*

*Right hand side*

*Horizontal mount only*

ADR - 49/00, 49/00, 6/00 (Cat 2a), 48/00  
CRN - 41006, 41986, 41988, 38228

# SUBMERSIBLE TRAILER LAMPS Series 202

- HIGH QUALITY LED'S (LOW POWER CONSUMPTION)
- POLYCARBONATE LENS
- TINNED WIRING & STAINLESS STEEL FITTINGS
- VIBRATION & SHOCK RESISTANT
- BUILT IN REFLEX REFLECTOR
- **12 VOLT ONLY**
- CABLE LENGTH (300mm)
- ADR APPROVED
- DIMENSIONS - 162mm x 80mm x 35mm

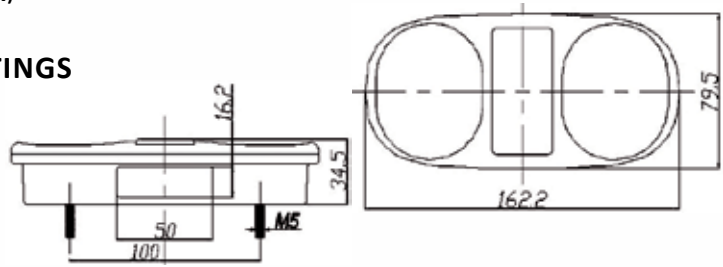

**12 VOLT ONLY**

**BR202L** Blister pack  
**EL202ARL** OEM pack

*Stop/tail & indicator  
Left hand side*

ADR - 49/00, 49/00, 47/00, 6/00 (Cat 2a)  
CRN - 40973, 40974, 40972, 40205

**12 VOLT ONLY**

**BR202R** Blister pack  
**EL202ARR** OEM pack

*Stop/tail & indicator  
Right hand side*

ADR - 49/00, 49/00, 47/00, 6/00 (Cat 2a)  
CRN - 40973, 40974, 40972, 40205

**12 VOLT ONLY**

**BR202NP** Blister pack  
**EL202ARNP** OEM pack  
*Horizontal fitting only*

**BR202VNP** Blister pack  
**EL202VNP** OEM pack  
*Verticle fitting only*

*Stop/tail, indicator & n/plate  
Right hand side*

ADR - 49/00, 49/00, 47/00, 6/00 (Cat 2a), 48/00  
CRN - 41145, 41141, 41148, 41147, 40205

# SUBMERSIBLE TRAILER LAMPS Series 202

- HIGH QUALITY LED'S (LOW POWER CONSUMPTION)
- POLYCARBONATE LENS
- TINNED WIRING & STAINLESS STEEL FITTINGS
- VIBRATION & SHOCK RESISTANT
- BUILT IN REFLEX REFLECTOR
- **12 VOLT ONLY**
- CABLE LENGTH (section 1 - 750mm, section 2 - 1600mm, section 3 - 5000mm)
- ADR APPROVED
- DIMENSIONS - 162mm x 80mm x 35mm

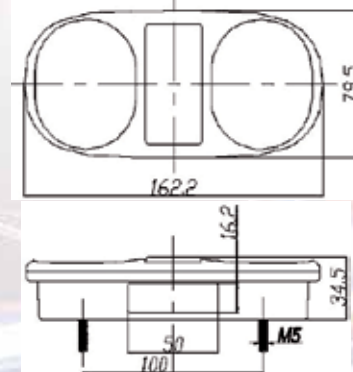

**12 VOLT ONLY**

**BR202TP** Blister pack  
*Stop/tail, indicator & number plate  
Twin pack (1x EL202AR & 1x EL202ARNP & wiring loom)*

ADR - 49/00, 49/00, 47/00, 6/00 (Cat 2a), 48/00  
CRN - 41145, 41141, 41148, 41147, 40205, 40973, 40974, 40972

# MARKER LAMPS Series 1 & 2

- HIGH QUALITY LED'S (LOW POWER CONSUMPTION)
- POLYCARBONATE LENS
- TINNED WIRING (2 CABLE LENGTHS AVAILABLE)
- VIBRATION & SHOCK RESISTANT
- MULTI VOLTAGE 10-30V
- ADR APPROVED
- DIMENSIONS - 60mm x 30mm x 22mm

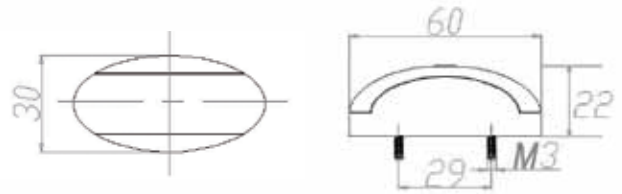

<i>Side position marker Amber/red</i>	<i>Side indicator marker Amber</i>	<i>Rear position marker Red</i>	<i>Front outline marker White</i>
<b>0.5 Metre Cable</b>	<b>0.5 Metre Cable</b>	<b>0.5 Metre Cable</b>	<b>0.5 Metre Cable</b>
<b>BR1AR</b> Blister pack (1) <b>OL-1(0.5)</b> OEM pack (10) pre-wired with 0.5m cable	<b>BR1A</b> Blister pack (1) <b>OL-2(0.5)</b> OEM pack (10) pre-wired with 0.5m cable	<b>BR1R</b> Blister pack (1) <b>OL-3(0.5)</b> OEM pack (10) pre-wired with 0.5m cable	<b>BR1W</b> Blister pack (1) <b>OL-4(0.5)</b> OEM pack (10) pre-wired with 0.5m cable
<b>2.5 Metre Cable</b>	<b>2.5 Metre Cable</b>	<b>2.5 Metre Cable</b>	<b>2.5 Metre Cable</b>
<b>BR2AR</b> Blister pack (1) <b>OL-1(2.5)</b> OEM pack (10) pre-wired with 2.5m cable  <small>ADR - 45/00 CRN - 41731</small>	<b>BR2A</b> Blister pack (1) <b>OL-2(2.5)</b> OEM pack (10) pre-wired with 2.5m cable  <small>ADR - 6/00 (Cat 2a) CRN - 40740</small>	<b>BR2R</b> Blister pack (1) <b>OL-3(2.5)</b> OEM pack (10) pre-wired with 2.5m cable  <small>ADR - 49/00 CRN - 40214</small>	<b>BR2W</b> Blister pack (1) <b>OL-4(2.5)</b> OEM pack (10) pre-wired with 2.5m cable  <small>ADR - 49/00 CRN - 40223</small>

# REFLECTORS

- SELF ADHESIVE
- DIMENSIONS - 65mm x 30mm x 8mm

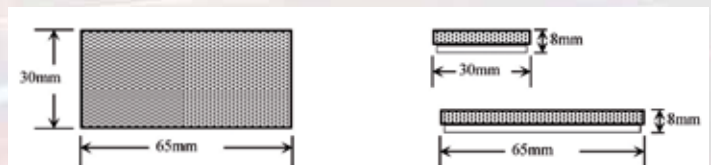

<b>BRREFR</b> Blister pack (2) <b>ELREFR</b> OEM pack (100) <i>Red reflector</i>  <small>ADR - 47/00 CRN - 40205</small>	<b>BRREFA</b> Blister pack (2) <b>ELREFA</b> OEM pack (100) <i>Amber reflector</i>  <small>ADR - 47/00 CRN - 40219</small>	<b>BRREFW</b> Blister pack (2) <b>ELREFW</b> OEM pack (100) <i>White (clear) reflector</i>  <small>ADR - 47/00 CRN - 40215</small>



# **BRYTEC**

## **BRYTEC PTY LTD**

UNIT 5, 5 KELLETTS ROAD  
ROWVILLE VIC 3178

PH: (03)9763 0911  
FAX: (03)9763 4233  
sales@brytec.com.au

<http://www.brytec.com.au>

### **Catalogue Information**

The product information detailed within this publication represents a portion of the products, as new products and upgraded development may be added at a later date without notification.

Brytec Pty Ltd reserves the right to add to, or delete from, or change the specifications of any product featured in this catalogue without prior notification. All product information detailed in this catalogue publication is, to the best of our knowledge and belief, correct at the time of print.

Brytec Pty Ltd shall not accept liability of any kind arising out of misuse of any product, or use for any other purpose than its intended use as indicated in this catalogue.



*Version V1.2*

Distributed By

